



T-LED s.r.o. , Gabinova 867/9, Praha 5
provozovna : Žitná 23/610, 110 00 Praha 1
Česká republika
IČ: 28916913 DIČ: CZ28916913
tel: 223 000 247, GSM: 734 543 813
www.t-led.cz info@t-led.cz

Katalogový list spínaný zdroj pro LED

Model TLPC-12-60, TLPC-24-60 12-24V 60W

MODEL		TLPC-12-60		TLPC-24-60	
Output	DC voltage	CH1:13.8V	CH2:13.4V	CH1:27.6V	CH2:26.5V
	Voltage tolerance	± 1%	-----	± 1%	-----
	Rated current	4.0A	0.35A	2.0A	0.25A
	Current range	0 ~ 4A	-----	0 ~ 2A	-----
	Rated power	59.9W		61.8W	
	Ripple & noise	100mVp-p	-----	100mVp-p	-----
	DC voltage ADJ. range	CH1:11.3 ~ 14.9V		CH1:21.3 ~ 29.8V	
Setup, rise, hold up time	800ms,50ms,80ms/230VAC.1600ms,50ms,16ms/115VAC.				
Input	Voltage range	90 ~ 264VAC or 127 ~ 370VDC			
	AC current	1.6A/115VAC 0.8A/230VAC			
	Efficiency	81%		83%	
	Inrush current	cold-start current 25A/115VAC 45A/230VAC			
	leakage current	< 1mA/240VAC			
Protection	over load	rated output power 110% ~ 150% start over load protection protection type: AC charging mode :hiccup mode, auto-recovery after fault condition is removed			
	battery protection at low voltage	9.5 ~ 11V		20 ~ 22V	
Function	UPS introduction	long-term online floating charge to battery,high charging efficiency,battery can saturate to more than 90%			
		auto-stop charging when it's full,prevent over charging. Effectively extend battery life			
		AC/battery auto switch,no switch time,no need human guard			
		cold-start ,when there is no AC input ,can use battery start UPS,Meet the user's emergency needs			
Environment	Working temp, humidity	-10°C ~ +60°C;20% ~ 90%RH(Please refer to "derating curve")			
	Storage temp, humidity	-20°C ~ +85°C;10% ~ 95%RH Non-condensing			
	Withstand vibration	10 ~ 500Hz, 2G 10min./1Cycle, Period for 60min, Each axes			
Safety	Withstand voltage	I/P-O/P: 1.5KVAC I/P-FG: 1.5KVAC O/P-FG: 0.5KVAC			
	Isolation resistance	I/P-O/P: I/P-FG,O/P-FG: 100M Ohms/500VDC			
Fit standard	Safety standard	Compliance to UL60950-1			
	EMC Standard	Compliance to EN55022, CLASSB			
Others	Weight	0.52kg 129*96*38mm (L*W*H)			
	Packing	0.52kg/45pcs/24kg			

Note: 1. All parameters NOT specially mentioned are measured at 230VAC input, rated load and 25°C of ambient temperature.

2. Ripple & noise are measured at 20MHz of bandwidth by using a 12" twisted pair-wire terminated with a 0.1uf & 47uf parallel capacitor.

3. Tolerance : includes set up tolerance, line regulation and load regulation

Mechanical specification

Unit:mm

PIN assignment

Pin No.	Assignment
1	AC/L
2	AC/N
3	FG \perp

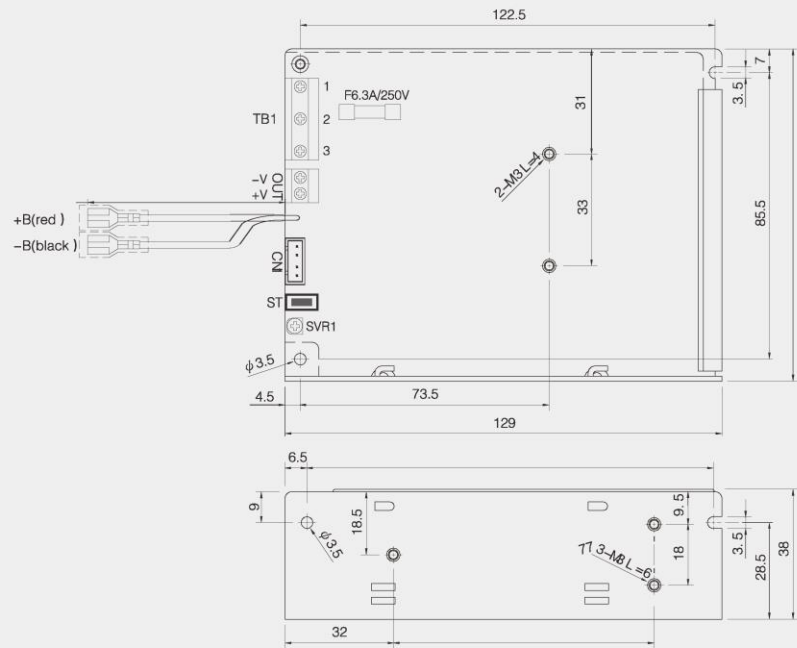

circumscribed indicator explain

indicator color	explain
green	DC OUTPUT indicator
red	AC INPUT indicator
white	battery charge indicator

cold-start ,when there is no AC input ,can use battery start UPS,Meet the user's emergency needs

Block diagram

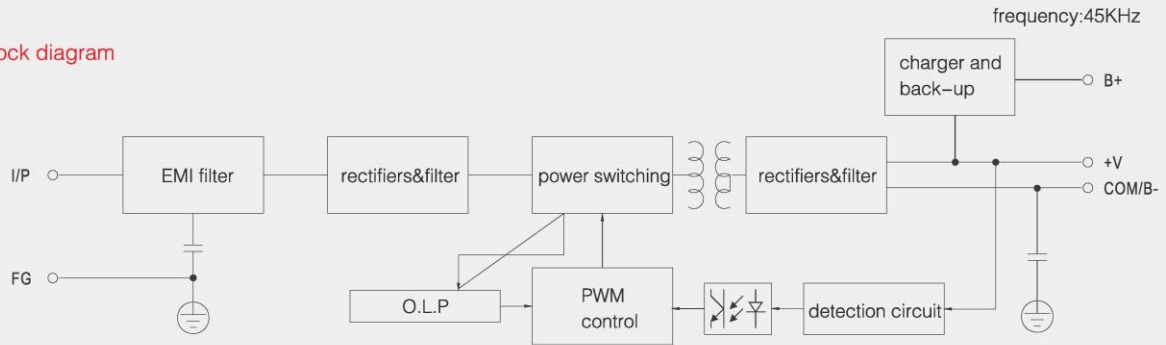

Derating curve

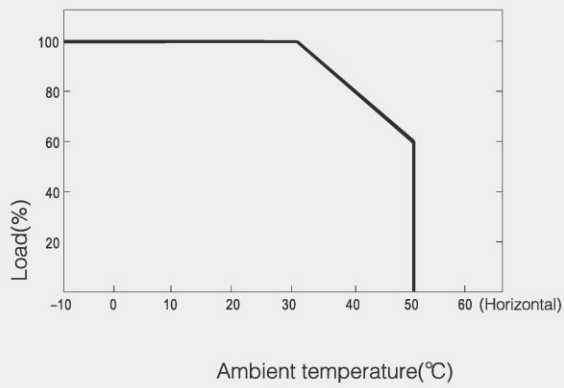

Static characteristic

